



Air Pollution Control Division

Technical Services Program

Appendix PM5

Standard Operating Procedure for the Chemical Speciation Network (CSN) – URG 3000N

This SOP is based on EPA's Standard Operating Procedure for the URG-3000N Sequential Particulate Speciation System Version 2.0 August 11, 2011.

PART I: URG3000N

Purpose and Applicability

This standard operating procedure (SOP) outlines procedures for field operations, regular maintenance, and monthly verification of the URG-3000N speciation sampler for local operators. For more detailed information regarding field installation, setup and operation of this sampler, refer to the URG-3000N Operations Manual.

Safety Precautions

Read, understand, and follow all safety precautions for the sampler outlined in the sampler's operations manual. Once sampler installation has been completed and the sampler is secured to a sampling platform it should not be moved. If the sampler needs to be moved, it will be performed by APCD personnel. Care must be taken when operating, cleaning, or verifying the units in inclement weather.

General Instructions

Read and thoroughly understand the operations manual before beginning field sampling operations. Prior to any flow rate or verification, a leak check must be performed as described in this document. NOTE: Exercise care in placement and **handling of sampling cartridges** to avoid contamination.

Figure Handling of Sampling Cartridge



A red cap cover should be placed on the bottom of each of the four cassettes during transport and handling. Avoid touching the filter media at any time, especially while loading and recovering the sample cartridge.

Personnel Qualifications

The APCD provides training to field personnel and local operators. APCD will only permit site operators to operate the URG 3000N samplers after passing an onsite proficiency evaluation at the time of sampler installation. The PM2.5 Program Coordinator, or other qualified APCD personnel, evaluate each operator's proficiency after each site operator has been given sufficient time to review the SOPs and

practice on the URG 3000N sampler. If failure should occur during the evaluation, the APCD will provide onsite training until the local operator becomes proficient.

Instrument Overview

An image of the URG-3000N is presented here. The sampler consists of one sampler module, one controller, a stand, rain shield, and sample inlet. The controller houses the timer, keypad and electronics necessary to configure, calibrate, and operate the sampler. The stand contains the pump and flow controllers.

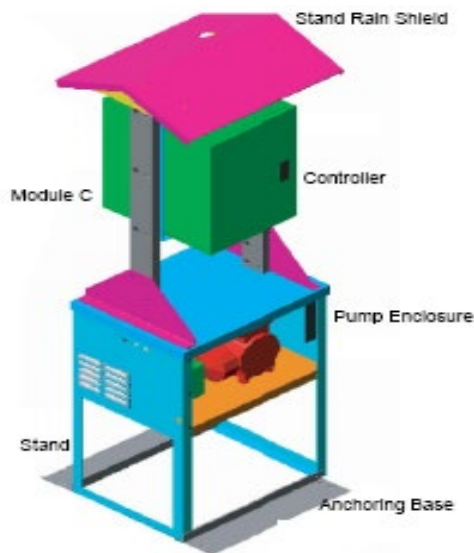

URG 3000N Controller Overview

The sampler controller is used to setup the sampler and manage all aspects of operation. The operator uses a 20-button keypad fitted with an LCD screen to interface with the controller. The keypad/screen is connected to the controller with a cable that allows the operator to move the keypad from its storage compartment to the front of the sampler when in use. The controller:

- Provides the current sampler status to the operator.
- Reports all data necessary for the setup and operation of the sampler.
- Enables the operator to define sampling protocols (e.g. schedule).
- Records and reports the date and time.
- Manages the active flow control.
- Averages and records critical sample data such as ambient pressure and ambient temperature to a Compact Flash card.

Module C Overview

The components of the sample Module C are identified here (below), along with the flow diagram.

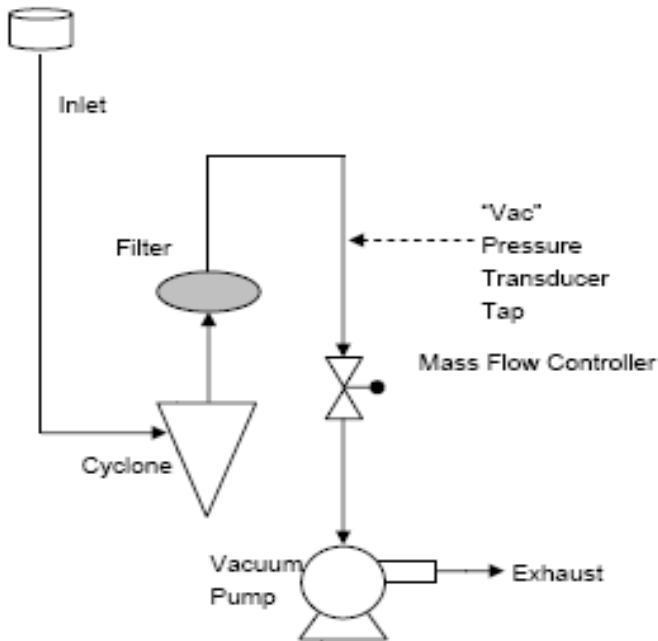
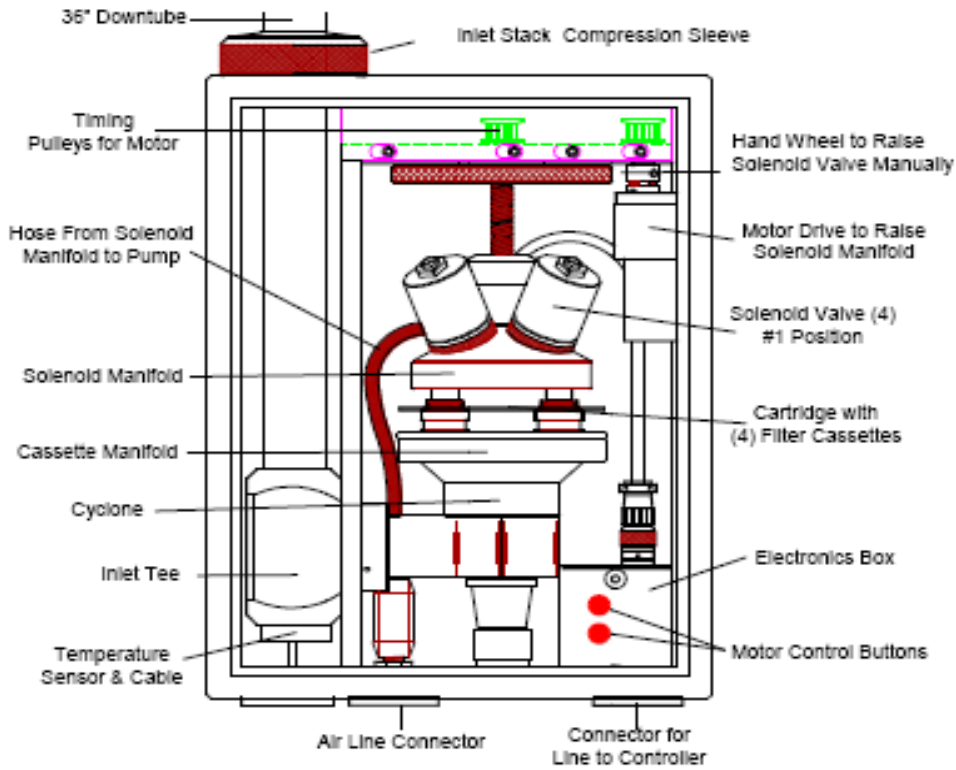

The ambient air enters the sampler through a screened inlet on top of the down tube. The inlet precludes insects, rain, and particles greater than 15 μm from entering the sample flow. The sample then passes through a cyclone that excludes particles larger than 2.5 μm . The cyclone is rated to remove 50% of particles larger than 2.5 μm at a flow

rate of 22.0 Lpm. The flow is metered using a mass flow controller (MFC) with adjustments made for actual temperature and pressure. The temperature probe is inserted in the inlet tee and is situated in the sample flow upstream of the cyclone.

Filter Cassettes and Cartridges

The sample cartridges used are manufactured specifically for this sampler and prepared by the CSN contract lab. Each cartridge has a center hole and an alignment hole to aid the operator with the correct cartridge alignment.

Pump Compartment

The pump compartment houses the sample pump and flow controller. The components are:

- Pump Enclosure Fan – used to regulate the temperature within the enclosure.
- Mass Flow Controller – used to regulate sample flow.
- Power Terminal – used to provide power to the sample pump and enclosure heater

Installation Overview

The instrument is installed, configured, and calibrated by the CSN installation contractor during the initial setup, all subsequent calibrations and sampler relocations are only performed by trained APCD personnel. For details regarding the initial installation and configuration see the URG-3000N Operations Manual.

Procedures for Routine Filters Change-out and Configuring Sampling Events

The URG-3000N sampler is designed to sample on a 1-in-3 day or a 1-in-6 day schedule. When the sampler is installed and the date and time are set correctly the sampler is set to a 1-in-3 day or 1-in-6 day default schedule, as appropriate. The sample also can be programmed to run on an alternative sample date. For any other programming issues please see the URG-3000N Operations Manual.

The sampler software identifies two types of filters, Exposed Filter and New Filter. The Exposed Filter is the filter in the sampler from the previous sample run. The New Filter is the filter for the next sample run. See the two display screens below to understand where the designation (in bold) is on the screen. The Mod: [1] represents sampling from Module 1.

<p>New Filter Mod:[1] Flow Vac ET 21.8 140.6 0 Enter=Next</p>
--

<p>Exp. Filter Mod:[1] Flow Vac ET 22.2 147.1 1440 Enter=Next</p>
--

When the operator goes to the site to recover an exposed filter and set-up new sampling events, they should bring the following equipment and supplies.

1. Operations Manual or this SOP,
2. Quartz filter(s) in a filter cassette mounted on a filter cartridge in a 9" x 12" sealable plastic shipping bag (provided by the support laboratory),
3. Compact Flash memory card in a 3" x 4" anti-static sealable plastic shipping bag (provided by the support laboratory),
4. PM_{2.5} CSN Custody and Field Data Form (CUSTODY FORM) provided by the support laboratory,
5. PM_{2.5} STN Regular Maintenance/Sampler Verification Form

Filter Changing

It is highly recommended that the exposed filter be removed from the sampler within 48 hours after the sampling period ends. However, often the support laboratory does not provide replacement cartridges in a suitable time frame to recover the exposed cartridge within 48 hours. In these cases APCD recommends waiting until the operator has a replacement cartridge in hand prior to visiting the site.

Prior to opening the Controller or Sample Module doors, check for moisture buildup from rain or snow on the sample housing; remove as necessary. Make a comment in the appropriate section of the CUSTODY FORM.

Open the Controller Module and confirm that the sampler has power by viewing the display screen. The AUTO MODE screen (see below) should be visible.

4/2/2009 10:58am THUR
 Next samp:COMPLETED
 Sampler is OFF

The keypad has an extension cord and magnetic strips. Remove the keypad from its holder and move it with attached extension cord to the front of the Sample Module. Open the Sample Module door and attach the keypad (magnetic strips) to the inside of the Sample Module door.

Inspect the Sample Module for moisture and wipe it out with a laboratory tissue if necessary. Inspect the seating around the filter manifold and filter cassette. Report the findings on the CUSTODY FORM and field notebook.

From the AUTO MODE (default) display screen (above), record the sample cartridge removal date and time on the appropriate CUSTODY FORM in the Retrieval Date and Retrieval Time columns.

Use the Filter Change and Scheduling Menu Tree. Begin by pressing the “**ENTER**” key. The display screen below should appear.

F1=Change Filter
 F2=Set Date & Time
 F3=Alt. Sample Day
 F4=More ENTER=Auto

Press the “**F1**” key and then the “**YES**” key to proceed to the filter change menu. The sampler will read the ambient temperature and barometric pressure for the Exposed Filter and record the information on the Compact Flash memory card. After a brief pause, the pump will start (see the screens below).

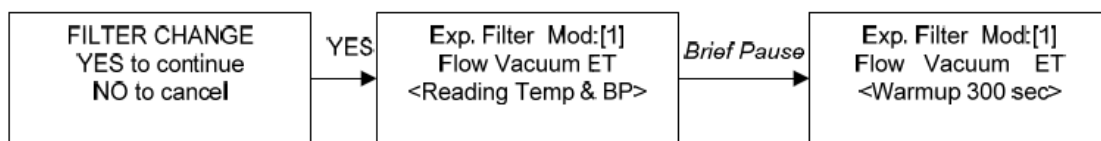

After five minutes, the program will show the final flow rate and vacuum pressure. Press the “**ENTER**” key, and the final flow rate values will be stored for the Exposed Filter on the memory card (see screens below).

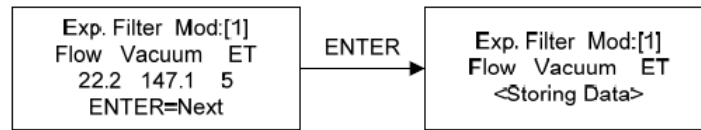

After a brief pause, the program will display the sampling results for the Exposed Filter. These results are stored on the memory card and should be transcribed to the CUSTODY FORM assigned to the Exposed Filter.

The first screen (below) shows the elapsed time for the Exposed Filter sampling event. Record this value (*1445 minutes*) in the Run Time column on the CUSTODY FORM. An accepted sample run is 24 hours \pm 1 hour. If the elapsed time was less than 1380 minutes or more than 1500 minutes, record "YES" in the Run Time Flag column, notify APCD. The time elapsed during the final flow rate and vacuum check is added to the total sample time.

```

Elapsed Time
[1] 1445 minutes

F4=More
  
```

The sampler is configured to start at midnight and run until midnight the following day. The URG-3000N does not display the Start Date, Start Time, End Date, or End Time on the display screens, consequently the operator will need to determine the Stop Time and Stop Date based on the elapsed time.

Press the "F4" key to advance to the next screen, which shows the sample volume (screen shot below). Report the sample volume on the CUSTODY FORM under the Sample Volume column.

```

Sample Volume
[1] Volume = 30.12

F4=More
  
```

Press the "F4" key to view the flow average (*22.1 L/min*) and the coefficient of variation (CV) in percent (*0.1*). Report the flow average and CV on the CUSTODY FORM under the Average Flow and Average CV columns.

```

Flow Average and CV
[1]AVG= 22.1 CV= 0.1

F4=More
  
```

Press the "F4" key to view the average (*25.0 °C*), maximum (*26.1 °C*), and minimum (*24.3 °C*) ambient temperatures during the sample run. Report these results on the CUSTODY FORM under the Average Ambient Temperature, Maximum Ambient Temperature, and Minimum Ambient Temperature columns.

```

Temperature
AVG= 25.0 (C)
MIN= 24.3 MAX= 26.1
F4=More
  
```

Press the “**F4**” key to view the average barometric pressure during the sample run. Report these results on the CUSTODY FORM under the Average Barometric Pressure, Maximum Barometric Pressure, and Minimum Barometric Pressure columns.

```
Barometric Pressure
AVG=738.8 (mmHg)
MIN=734.5 MAX=739.0
ENTER=Done
```

After displaying the Exposed Filter data, the controller will prompt the operator to replace the memory card (see screen below). Replace the old memory card by pulling lightly (see below) and placing a new memory card provided by the support laboratory. The memory card will only fit in the memory card slot one way. Do not force it into the slot. Place the old memory card in a 3” x 4” anti-static sealable plastic shipping bag provided by the support laboratory. The file name for the sample run on the memory card will begin with “r”.

```
Replace controller's flash
card.

ENTER=Done
```

Press the “**ENTER**” key and the system will reset briefly showing the URG-3000N boot screen (below).

```
URG-3000N
Sequential Particle
Speciation System
YYYY.MM.DD
```

The sampler will check the new memory card. If the card is found to be OK it will continue to the New Filter Menu (see screens below).

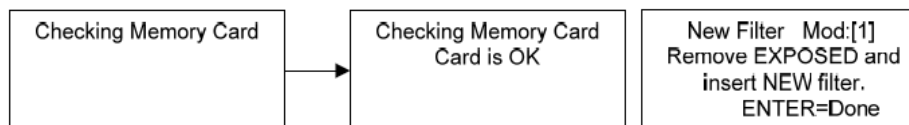

If the card is not found, the operator will have the option to run the sampler with no card (not recommended in the CSN program) or test the card again. If the sampler still does not recognize the card, use the old memory card and report issue on the CUSTODY FORM and report in the field notebook. Return the malfunctioned memory card to the support laboratory with the shipment in which it arrived and notify APCD. Alternatively, the operator can run the sample without a card, recording the sample data on the custody document.

The first screen in the New Filter Menu directs that the operator replace the Exposed Filter with the New Filter.

To remove the Exposed Filter cartridge, press the top “**up**” button on the electronic box to raise the solenoid manifold until the cartridge is released.

Grasp the filter cartridge with the bottom side down and place the red caps on all of the filter inlets. Place the cartridge in the 9” x 12” sealable plastic shipping bag provided by the support laboratory. Note: ***In cold weather, the motor may not move the manifold. In this case:***

1. Grasp the motor to the right of the solenoid manifold firmly and pull downwards.
2. Next, grasp the motor and swing it to the left.
3. You can now use the large wheel located above the solenoid manifold to manually raise and lower the solenoid manifold.

Place the 3" x 4" anti-static sealable plastic containing the Exposed Filter memory card in the larger 9" x 12" bag. This larger bag will be shipped to the support laboratory.

Prior to removing the New Filter cartridge from the sealable plastic shipping bag, check that all four filter inlets are covered with red caps. If any of these caps came off during shipping, please note on the CUSTODY FORM for the New Filter. Remove the New Filter cartridge from the sealable plastic shipping bag provided by the support laboratory. Align with the hole forward as below to the left. Insert the cartridge into the cassette manifold and press the bottom "down" button on the electronic box to lower the solenoid manifold until it stops. Note: ***In cold weather, the motor may not move the manifold. In this case, move the manifold by rotating the large knurled wheel above the solenoids.***

Press the "ENTER" key to advance to the next screen, below. This screen allows the operator to input the Q Number (sample identifier number) for the New Filter. The Q Number for the New Filter can be found at the top left of the CUSTODY FORM. Using the keypad, enter the Q Number. The cursor on the display screen indicates where you are entering information. Verify your entry.

Q Number (New)
Q_
ENTER=Done

Press the "ENTER" key to advance to the next screen, below. This screen allows the operator to input the Comp ID Number for the New Filter. The CUSTODY FORM identifies two Comp ID Numbers; the operator is to use the keypad to enter the Comp ID Number for the Quartz cartridge. The cursor on the display screen indicates where you are entering information. Verify your entry.

Comp.ID Number (New)
I_
ENTER=Done

Press the "ENTER" key to advance to the next screen, below. The sampler will read the ambient temperature and barometric pressure for the New Filter and record the information on the Compact Flash memory card. The MFC will warm up for 10 seconds to conduct an initial vacuum check (see the screens below). Note: The operator must press the 'ENTER' key to proceed and minimize the amount of air the new filter is exposed to prior to the actual sample.

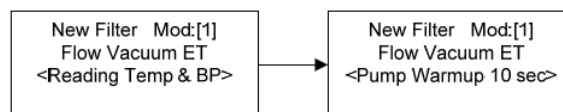

After a brief pause, the program will show the final flow rate and vacuum pressure.

Press the "ENTER" key, and the final flow rate values will be stored for the Exposed Filter on the memory card (see screens below).

If the measured vacuum pressure is less than 50 mm Hg, the sampler will generate a warning. Verify that the sample cartridge is installed correctly and that all connections are secure. Follow the instrument prompts to repeat the test. Should the warning repeat, perform a leak check as described in this SOP.

Note the warning on the CUSTODY FORM and PM2.5 STN Regular Maintenance/Sampler Verification Form.

If you do not press “ENTER”, the pump may continue to run. Consequently, press the “ENTER” to stop the pump and air flow after the disposition of the vacuum is ascertained so that the filter is not exposed unnecessarily.

After a satisfactory vacuum check has been obtained, press the “ENTER” key and the sampler will return to the AUTO MODE menu, shown below. The sampler will begin sampling at midnight on the listed date, here.

1/26/07 09:26pm WED Next samp: 01/27/07 Sampler is OFF
--

Shipping the Sample

Protect the sample during transport to and from the site. Store them, along with the sample modules from the SASS, in a secure, refrigerated area until just before packaging them in the cooler. Ship them with the SASS modules back to the laboratory as per normal procedure.

Generation of 24-hour Field Blanks

The procedure for sampling the field blanks has not been determined. When an approved procedure has been accepted, steps will be added to the SOP. The current plan is to place a “BLANK” filter in the Number 4 position on the filter cartridge. As a natural consequence of the procedure, the filter will remain in the Sampler for the 24-hour routine sampling, plus recovery time.

Generation of Trip Blanks

The frequency of Trip blanks will be recommended by the PM2.5 CSN Quality Assurance Project Plan. Trip blanks are used to measure possible contamination to filters during transportation to and from sampling locations. They provide a frame of reference in case field blanks exhibit mass gain higher than the tolerance levels. Trip blanks should remain inside their protective bags and never be exposed to sampling procedures. Trip blanks have been historically issued at a rate of approximately **5%** of all routine filters issued by the contractor laboratory support. The historical values have been quite low so the frequency may be reduced further as soon as a new record can be established with the URG 3000N. Trip Blanks are designated by the weighing laboratory and issued at random.

1. The trip blank should remain in their 9” x 11” anti-static, self-sealing plastic cassette bag at all times.
2. Transport the trip blank from the vehicle to the sampling location and return it to the transport container cooler. **Do not leave the trip blank inside the sampler during the sampling event.**
3. Make sure that the trip blank is properly indicated on the CUSTODY FORM.

Sampler Verification

Introduction

Prior to the first use of the sampler and every four weeks thereafter, conduct verifications of ambient temperature, barometric pressure, and flow rate according to the schedule provided by APCD. ***Always use verification standards provided by APCD. Allow the pump and MFC ample time to warm up before performing a flow verification.***

Use a PM2.5 STN Regular Maintenance/Sampler Verification Form to record and report results of the verification. See Figure at the end of this document. Also, have a copy of the URG 3000N Operations Manual on hand.

Equipment and Supplies for Routine Sampling and Sampler Performance Verifications

Prior to conducting a verification or routine sampling event, the field scientist must gather the necessary equipment and supplies for the specified procedures. Below is a list of those supplies.

1. Obtain a CUSTODY FORM and PM2.5 STN Regular Maintenance/Sampler Verification Form for the URG-3000N Sampler.
2. URG-3000N sampler operations manual.
Before beginning the verification, perform a filter change and put the instrument into "auto" mode. Use the new cartridge for the leak check and verification. For routine sample runs, the cartridge with cassettes and quartz sampling filters will be supplied by the support laboratory.
3. Temperature, pressure and flow standards.
4. Use a cell phone or verify the current time at www.time.gov.
5. Bring the leak check assembly provided by URG, specifically:
 - a.) Down tube reducer (1.5"ID to 1.25"OD),
 - b.) Leak check adaptor (1.25" to brass hose barb with shutoff valve)
 - c.) Pump shutoff valve assembly (This assembly will be hard-plumbed into later models of the URG 3000N)

AUTO MODE to AUDIT Menu Screens

The image below displays the menu screens from the AUTO MODE screen to the Audit Menu. The first menu screen displayed is the AUTO MODE screen. From this screen, press the "**ENTER**" key to move to the Authentication screen. Then enter "**1123**" to proceed to choose the Operator screen. Select the appropriate operator by their initials; the primary operator is "**1**", the backup operator is "**2**", and the auditor is "**3**". These values will be set up when the sampler is installed. Selecting "**1**, **2**, or **3**" keys will forward the instrument to the next screen. Select the "**F4**" key to proceed to the next screen, the second Main Menu. At the second Main Menu, press the "**F3**" key for the Audit Menu.

Menu Tree from AUTO MODE Screen to Audit Menu Screen

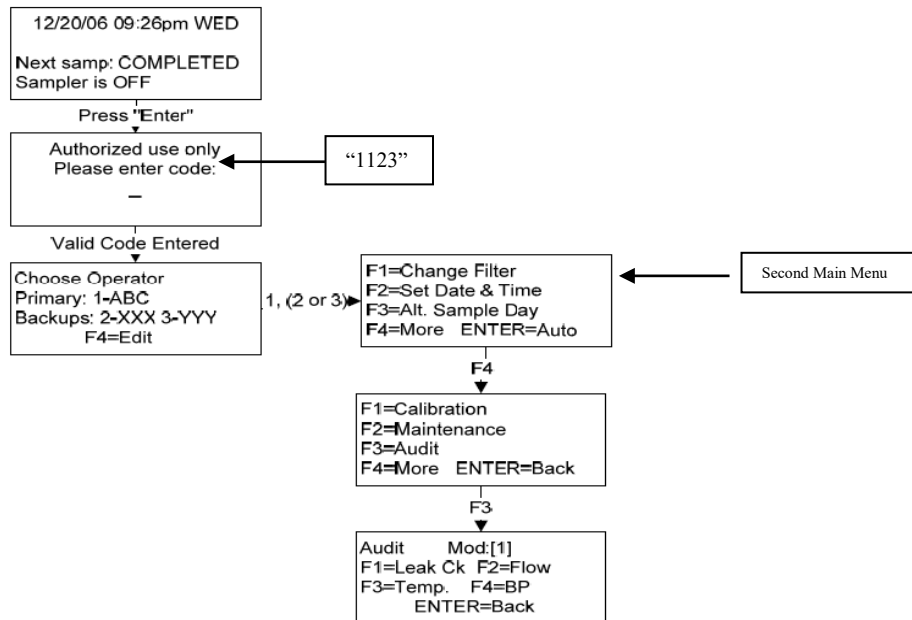

Ambient Temperature Verification

At the base of the inlet tee, locate the ambient temperature probe (see image).

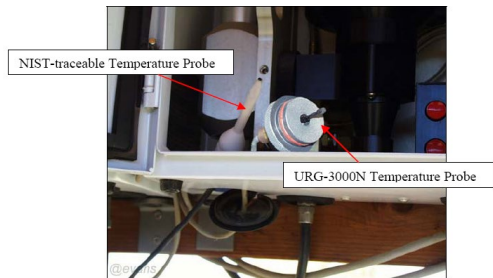

While holding the ambient temperature probe cable, gently push the black plastic disc through the bottom of the Sample Module.

With one hand reach into the sample module box and carefully wiggle the probe plug free from the inlet tee and lay it in the bottom side of the sample module box away from direct sunlight.

Place the verification temperature probe adjacent to the sampler's ambient temperature probe and allow both temperature probes to equilibrate, making sure to protect the probes from sunlight and wind so as not to create temperature fluctuations.

At the Audit Menu, press the "F3" key to proceed to the ambient temperature verification (audit) screen, shown here:

```
Audit Temperature
Temperature(C)= 25.4
F1:+/-  F2:C/F
Ref. Temp(C):?
```

After the two probes equilibrate, enter in the reference standard temperature value in degrees Celsius. Press the “F1” key to toggle between positive and negative values; press the “F2” key to toggle between Celsius and Fahrenheit. The decimal place is fixed to one place, so entering “254” will represent 25.4 °C.

Record the sampler and reference standard values in degrees Celsius on the Field Verification Form. **The agreement should be within ±2 °C.** If the values do not agree within the acceptance criteria then verify the readings and notify APCD personnel.

After entering the reference standard’s temperature, the next screen shows the sampler’s temperature, reference standard’s temperature, and the difference between the two values in Fahrenheit and Celsius (see example screen below).

```
C/F Samp. Ref. Diff.
C 25.4 25.0 0.4
F 77.7 77.0 0.7
ENTER=Next
```

Press the “ENTER” key to proceed to the next screen. Press the “YES” key to save audit results to the memory card. If the operator selects the “NO” key, no data will be saved and the sampler software will return to the Audit Menu screen. By selecting “YES”, the next screen appears (this screen could take a few moments to appear).

```
Save audit results to
memory card?
YES=Save NO=Cancel
↓
Audit results saved to
memory card.
ENTER=Next
```

YES

Press the “ENTER” key to return to the Audit Menu.

Remove the temperature standard and securely replace the sampler’s temperature probe in the bottom of the inlet tee. Replace the black plastic disc.

Barometric Pressure Verification

At the Audit Menu, press the “F4” key to proceed to the barometric pressure verification (audit) screen (see below).

```
Audit  Mod:[1]
F1=Leak Ck F2=Flow
F3=Temp.  F4=BP
ENTER=Back
→
F4  Audit BP
BP (mmHg)= 643.9
Ref. BP(mmHg):?
```

Enter the barometric pressure (in mm Hg) of an equilibrated NIST-traceable reference standard using the keypad. The decimal point is fixed to one place so entering ‘6245’ will represent 624.5.

Record the sampler and verification standard values in mm Hg on the Field Verification Form and the field notebook. **The agreement should be within ± 10 mm Hg.** If values do not agree within acceptance criteria verify the values and notify APCD.

After entering the reference standard's barometric pressure, the next screen shows the sampler's barometric pressure, the reference standard's barometric pressure, and the difference between the two values in mm Hg (see screen below).

Samp.	Ref.	Diff.
643.9	645.0	-1.1
ENTER=Next		

Press the “**ENTER**” key and select “**YES**” to save the results to the memory card. There will be a pause after you select ‘YES’ as the sampler writes the results to the card.

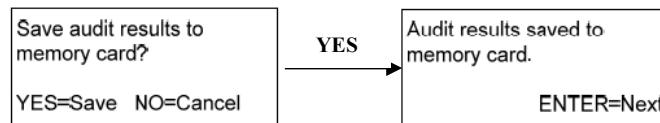

Press the “**ENTER**” key to return to the Audit Menu.

If the operator wishes to return to the AUTO MODE, press the “**ENTER**” key twice. To continue with a leak check and flow rate verification, continue in this SOP.

Leak Check

At the Audit Menu, press “**F1**” and “**ENTER**” keys to begin the leak check (see below).

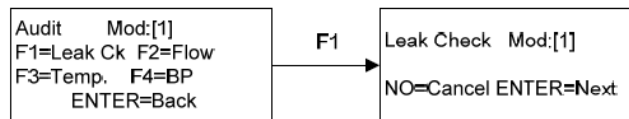

Remove the inlet cap from the top of the down tube, place the reducer on the down tube and install the flow audit adapter, make sure it's in the open position, as demonstrated below.



Press the “**ENTER**” key to continue with the leak check. The screen below requests that the operator install the pump shutoff valve in the open position. **NOTE: Samplers produced post-2006 have the pump shut-off valve plumbed into the instrument, consequently this step is automatically performed for the operators.**

Leak Check Mod:[1]
 Install pump shutoff
 valve (valve open)!
 NO=Cancel ENTER=Next

Inspect and assure the pump shutoff valve is in the open position. Disconnect the vacuum line from the side of the pump enclosure. Connect the pump shutoff valve to the vacuum (air) line and reconnect it to the side of the pump enclosure, demonstrated here.



Press the “ENTER” key to continue with the leak check. The software screen will now display that both valves are open, the pump is warming up, and a vacuum and time value, which will count down from 15 to 0 seconds (see below).

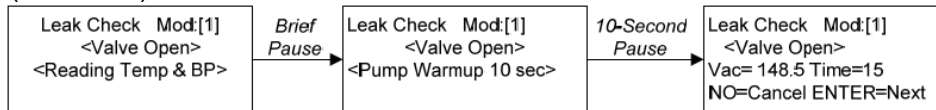

Press the “ENTER” key to continue to the next screen. This screen below requests the operator to close the flow audit adapter at the top of the down tube.

Rotate the lever on the flow audit adapter 90° to close the **flow audit adapter**. This will begin creating a vacuum in the down tube, through the sampler, to the pump.

Press the “ENTER” key to continue to the next screen. The vacuum will begin to increase and at a point near 680 mm Hg, the time will begin to count down from 15 to 0.

Leak Check Mod:[1]
 <Valve Closed>
 Vac=655 Time=15
 NO=Cancel ENTER=Next

After the countdown reaches zero, press the “ENTER” key and close the pump shutoff valve.

Leak Check Mod:[1]
 Close pump
 shutoff valve!
 NO=Cancel ENTER=Next

Press the “ENTER” key, and the pump will stop and the leak check will begin. The vacuum will begin to drop and when it reaches 380 mm Hg and a timer will count for a maximum of 35 seconds.

After the 35 second count, the leak check result will be displayed as either PASSED or FAILED. The acceptance criterion is a vacuum drop of less than 225 mm Hg in 35 seconds. The timer will stop if the leak is large enough for the vacuum pressure to drop more than 225 mm Hg within 35 seconds.

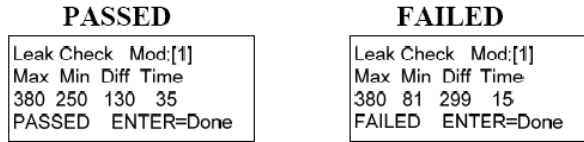

Record the pressure drop in mm Hg on the Field Verification Form and in the field notebook. If the sampler fails the leak check, attempt another leak check. If the sampler fails both times notify APCD.

Press the “ENTER” key to advance to the next screen, shown here.

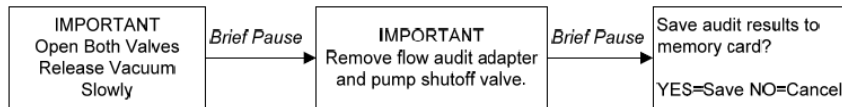

Slowly release the pressure in the sampler by slowly turning the lever on the flow audit adapter.
NOTE: Releasing the vacuum quickly may rupture the filter or pop it loose from the cassette and/or damage the filter. The next screen (above) will request the operator to remove the flow audit adapter and pump shutoff valve and reconnect the vacuum line. If the operator is going to perform flow rate verification, then the reducer can remain in place.

Press the “YES” key to save audit results to the memory card and “ENTER” to return to the Audit Menu.

If the operator wishes to return to the AUTO MODE, press the “ENTER” key twice. To continue with the flow rate verification, see below.

Flow Rate Verification

Prior to conducting flow rate verification, a successful leak check must be completed (see previous). The operator should use the flow transfer standard provided by APCD (equilibrated to ambient conditions). The flow rate verification should be conducted with the “AUDIT” cartridge.

At the Audit Menu, press the “F2” key to proceed to the flow rate verification (audit) screen and select “YES” to continue with the flow verification.

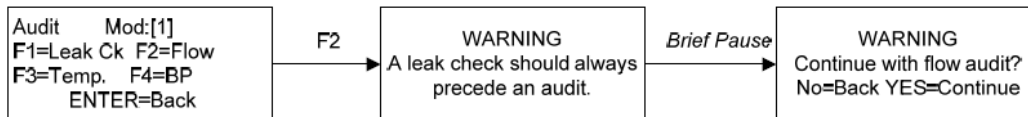

Check the connections to the flow transfer standard, and press the “ENTER” key to continue. The pump will turn on after a brief pause and the following screen appears:

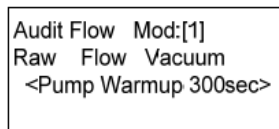

The MFC will run for 5 minutes (300 seconds) at the samplers design flow rate of 22.0 L/min to allow the pump to warm up. At the end of the 5-minute warm up period, the screen below will appear showing the sampler’s flow rate and vacuum at that time. **NOTE: At this point it may not be necessary to accommodate the entire 300 seconds of pump warm-up. If the operator wishes to proceed without the entire 300 seconds simply press “ENTER” at any point during the Pump Warm-up.**

Press the “**ENTER**” key to continue to the next screen. In the screen below, the operator is prompted to enter the reference standard’s flow rate in L/min. Use the keypad to enter the reference standard’s flow rate value. The decimal place is fixed at two decimal places, so for a flow rate of 21.95 L/min., enter “**2195**”.

```
Audit Flow Mod:[1]
Raw Flow Vacuum
3052 21.95 147.9
Ref. Flow(LPM):?
```

Note: APCD uses the following equation to calculate flow measured with an APCD FTS:

$$Q = m * \sqrt{\Delta H_2O * (T_a + 273) / (\frac{P_a}{760})} + b$$

WHERE

Q = flow, L/min

m = FTS slope, printed on side of flow transfer standard

b = FTS intercept, printed on side of flow transfer standard

T_a = current ambient temperature, °C

P_a = current ambient pressure, mmHg

ΔH₂O = manometer pressure drop, inches of H₂O.

After entering the calculated flow transfer standard flow rate, the screen below appears showing the sampler’s flow rate, the reference standard’s flow rate, and the difference (sampler – reference standard) between the two values (all in L/min).

Record the sampler and reference standard values in L/min on the Field Verification Form and in the field notebook. The calculated flow should be 22.0 ± 2 L/min (i.e. from 24 to 20). If the flow rate falls outside of this range notify APCD.

Press the “**ENTER**” key to proceed to the next screen, select “**YES**” to save the audit results to the memory card, press “**ENTER**” to return to the Audit Menu, shown here.

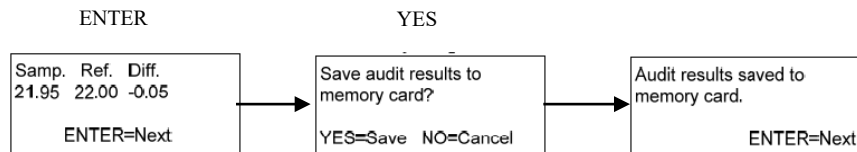

Note the pump will not shutdown until all the reference flow rates have been recorded.

Return the sampler to the AUTO MODE by pressing “**ENTER**”. The verification is now completed and the operator must make sure the sampler is back in the correct configuration. Remove the transfer standard and reducer from the down tube, reinstall the inlet cap. The operator must make sure to remove the audit cartridge and install the proper sampling cartridge. Configure or verify the current configuration of the next scheduled sampling event.

Sampler Calibration

The URG-3000N sampler can be calibrated for ambient temperature, barometric pressure, and flow rate. The calibration procedure should be performed if the sampler fails a verification check when it is initially installed. A calibration of any of the sampler’s parameters may be necessary if the sampler fails a monthly, quarterly, semiannual, or annual quality control check.

The overall procedures for performing a calibration are similar to the verification procedures on the URG-3000N with one major difference. The results from the verification checks are merely stored on the sampler's Compact Flash memory card. When a calibration of ambient temperature, barometric pressure, or flow rate is conducted, the results are also saved on the memory card, but will change the settings in the sampler for that parameter.

Before conducting a calibration, confirm the reference standards are certified as NIST-traceable and in good working condition. Allow the calibration standards to equilibrate to ambient conditions. Follow the procedures provided by the standard's manufacturer regarding the length of time for the standard to obtain stable conditions.

Since the operator is changing the ambient temperature, barometric pressure, and flow rate setting in the sampler, the changes must be well documented. Record all calibration information on a PM2.5 STN Regular Maintenance/Sampler Verification Form. To assist the operator through the proper calibration steps, have a copy of the sampler's operation manual or the Calibration, Maintenance, and Audit Menu Trees for assistance in performing the verification. From the AUTO MODE screen, Press the "ENTER" key to move from the AUTO MODE to the Authentication screen. Then enter "1123" to proceed to choose the Operator screen. Choose "1, 2, or 3" to proceed to the Main Menu screen. Press the "F4" key to show the second Main Menu. At the second Main Menu, press the "F1" key for the Calibration Menu screen (see screens for AUTO MODE to Calibration Menu in Figure 7.1 below). If the sampler does not respond after performing the proper ambient temperature, barometric pressure, and flow rate calibration procedures, refer to the Operations Manual and contact APCD for direction.

Ambient Temperature Calibration (1-Point)

At the base of the inlet tee, locate the ambient temperature probe. While holding the ambient temperature probe cable, gently push the black plastic disc through the bottom of the Sample Module. Slowly loosen the nut holding the ambient temperature probe and carefully remove the probe plug and set it inside the module, away from direct sunlight (exposing the probe to ambient conditions).

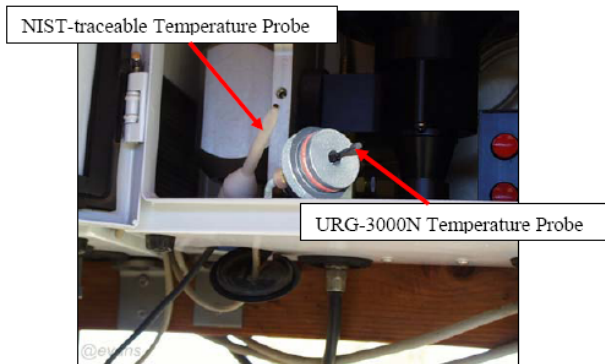

Place the reference temperature probe alongside the sampler's ambient temperature probe and allow both temperatures to equilibrate. If it is windy, it might be a good idea to place the probes into the module for reading. This will minimize interference from wind and sunlight.

Menu Tree from AUTO MODE Screen to Calibration Menu Screen

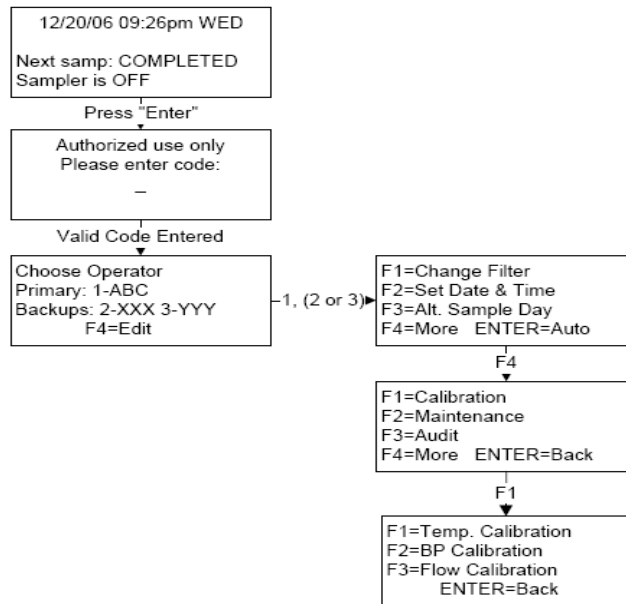

At the Calibration Menu, press the “F1” key to proceed to the ambient temperature calibration screen (see screen below).

Press the “SPACE” key to begin the ambient temperature calibration and the screen below will appear.

```

Raw Offset C  F
1457  0  20,0  68,0
F1: +/-  F2:C/F
Ref. Temp (C):?
  
```

After the two probes equilibrate, record the sampler and reference standard values in degrees Celsius on the CSN Calibration Form and the field notebook. **The agreement should be within ±2 °C.**

Enter the reference standard temperature value in degrees Celsius. Press the “F1” key to toggle between positive and negative values whereas pressing “F2” to toggle between Celsius and Fahrenheit. (Example: for 25.2 °C; enter “252”. The decimal place is fixed for a tenth degree). Press the “YES” key to save the results to the Compact Flash memory card. After a brief pause, the operator is returned to the Calibration Menu.

Remove the temperature reference standard and securely place the sampler’s temperature probe back in the bottom of the inlet tee. Replace the black plastic disc.

If the operator wishes to return to the AUTO MODE, press the “ENTER” key twice. To continue with a barometric pressure calibration, leak check and flow rate calibration continue below in this SOP.

Barometric Pressure Calibration (1-Point)

At the Calibration Menu, press the “F2” key to proceed to the barometric pressure calibration screen (see screens below). Press the ‘SPACE’ key to begin the ambient pressure calibration.

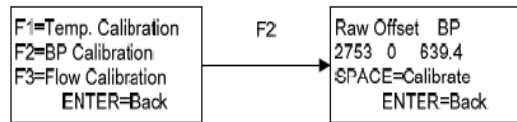

Record the sampler and the reference standard barometric pressure values in mm Hg on the CSN Calibration Form, the agreement should be within ± 10 mm Hg.

Enter the barometric pressure (in mm Hg) of an equilibrated NIST-traceable reference standard using the keypad. (Example: for 754 mm Hg; enter 7540, the display screen will show 754.0 mm Hg. The decimal place is fixed for a tenth degree. If you entered "754", the display screen will show 75.4 mm Hg which is incorrect.)

After entering the reference standard's barometric pressure, the next screen shows the sampler's calibrated barometric pressure (see screen below).

```

Calibration BP:
639,4 mmHg
Raw=2753 Offset 0
YES=Save No=Cancel
  
```

Press the "YES" key to save to the Compact Flash memory card (see below). After a brief pause, the operator is returned to the Calibration Menu.

If the operator wishes to return to the AUTO MODE, press the "ENTER" key twice. To continue with a leak check and flow rate calibration, continue in this SOP.

Flow Rate Calibration (3-Point)

Prior to conducting flow rate verification, a successful leak check must be completed. The operator should use a NIST-traceable calibration standard that has been equilibrated to ambient conditions. Follow the procedures provided by the standard's manufacturer regarding the length of time for the standard to obtain stable conditions. The flow rate calibration must be conducted with the "AUDIT" cartridge. See the section regarding the proper procedure for inserting the "AUDIT" cartridge. If the flow audit adapter is not connected to the top of the down tube, remove the inlet cap and place the flow audit adapter on the top of the down tube. Connect tubing from the reference standard to the flow audit adapter and begin the flow rate verification.

At the Calibration Menu, press the "F3" key and then the "ENTER" key to proceed to the flow rate calibration screen (see screens below).

A successful leak check must be performed before continuing with a flow rate calibration (leak < 225 mm Hg in 35 seconds). To continue with the flow rate calibration, press the "YES" key. Press the "ENTER" key to advance to the next screen and then press the "ENTER" key again to proceed to calibrate the first point.

Check connections to reference flow meter, and press the "ENTER" key to continue. The MFC initiates after a brief pause, the following screens appear.

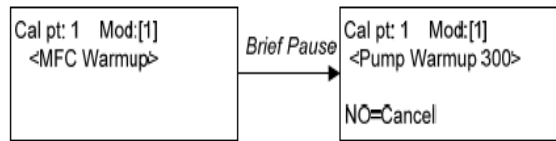

The MFC will run for 5 minutes at the first calibration flow rate of 19.80 L/min. At the end of the 5 minute warm up period the sampler's flow rate and vacuum will be displayed.

Press the “**ENTER**” key to continue to the next screen. In the screen below, the operator is prompted to enter the reference standard's flow rate in L/min. After the reference standard stabilizes, use the keypad to enter the reference standard's flow rate value. The decimal place is fixed at two decimal places so for a flow rate of 21.75 L/min., enter “**2175**”. Record the sampler and reference standard values in L/min for Calibration Point 1 on the CSN Calibration Form and the field notebook. **The agreement should be within +/-10%.**

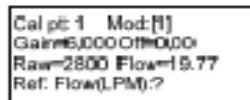

After entering the reference standard's flow rate for Calibration Point 1, the screen below appears showing the second calibration point of 22.00 L/min. Press the “**ENTER**” key. The MFC begins sampling at the second calibration point and displays the flow rate. After the reference standard stabilizes, use the keypad to enter the reference standard's flow rate value. Record the sampler and reference standard values in L/min for Calibration Point 2 on the CSN Calibration Form and the field notebook. **The agreement should be within +/-10%.**

Repeat the previous step with Calibration Point 3 (24.20 L/min).

After entering the reference standard's flow rate for Calibration Point 3, record the new Gain, Offset, and Correlation, shown here:

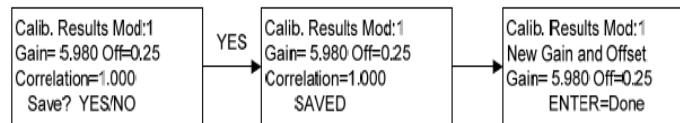

Press the “**YES**” key to save the flow rate calibration to Compact Flash memory card. Press the “**ENTER**” key to return to the Calibration Menu screen.

If the operator wishes to return to the AUTO MODE, press the “**ENTER**” key twice. This concludes the calibration of the URG-3000N sampler. The sampler is ready for sampling.

Regular Cleaning and Maintenance Activities

Maintenance

Record all maintenance activities in the site notebook. On the CUSTODY FORM record activities that may affect the sample weight or analysis. The URG-3000N is a new sampler and a complete maintenance schedule will be prepared and accessible in upcoming instruction manuals.

Every Visit

1. Check O-rings on each filter cassette for wear, damage, and proper seat.
2. Clean off any moisture (rain or snow) around the outside of the Sampler and Controller Modules.
3. Check for moisture inside the Sample Module.

Monthly

1. Examine O-rings – these should be replaced if there is significant evidence of wear – contact APCD to arrange replacements.
2. Clean the interior of the Sample and Controller Modules with Kim wipe tissues or paper towel to remove bugs, dirt, or water deposits.
3. Clean sampler inlet surfaces.
4. Remove, clean and replace the cyclone.

Cyclone Removal

In order to remove the cyclone, you must first release the filter cartridge by pressing the red “up” button on the electronic box. After removing the filter cartridge, follow the steps, above, to remove the electronic box. Note that the box does not have to be completely removed, but it is recommended. The black box located at the bottom-right of the Sample Module is known as the electronic box. This box contains the electronics that control the solenoid module. To remove it for servicing, follow the steps below.

1. First, remove the vacuum sensor tube by pressing in the quick-release adaptor and lifting at the same time. Next, reach behind it to remove the motor control cable by twisting the metal nut counter-clockwise.
2. Remove the 12-pin controller cable from the bottom of the Sample Module which is connected through to the electronic box.
3. Unscrew the two brass-headed bolts in the front of the electronic box.
4. Now remove the electronic box.

Now remove the cyclone by unscrewing the ring that connects the cyclone to the inlet tee. Then lift up and carefully remove the cyclone and cassette manifold body. Pull the grit cup off of the bottom of the cyclone and clean it out with alcohol and a shop towel. Use a bottle of compressed air to blow out any dust inside the cyclone body. Reconstruct the set up by reversing these steps.

Quarterly Maintenance

1. Inspect O-rings and apply a light coat of vacuum grease if required.
2. Clean the interior of the Sample and Controller Modules with Kimwipe tissues or a paper towel to remove bugs, dirt, or water deposits.
3. Check all Tygon tubing and vacuum lines; replace if dry or cracked and if necessary.
4. Clean sampler inlet surfaces.
5. Inspect electrical line connections.
6. Clean sampler inlet tube by pushing a slightly moistened paper towel with a wooden dowel through the inlet tube. Allow to dry before using inlet tube.

General Service Routines

Manually Moving the Solenoid Manifold

To manually move the solenoid manifold, follow the steps below. Note that you can remove the solenoid manifold completely for servicing by lowering it fully using the wheel.

1. Grasp the motor to the right of the solenoid manifold firmly and pull downwards.
2. Next, grasp the motor and swing it to the left.
3. You can now use the large wheel located above the solenoid manifold to manually raise and lower the solenoid manifold.

Electronic Box

The black box located at the bottom-right of the Sample Module is known as the electronic box. This box contains the electronics that control the solenoid module. To remove it for servicing, follow the steps below.

If any electrical connections are disconnected, make sure cables and sockets are color-coded or otherwise labeled for subsequent reconstruction.

1. First, remove the vacuum sensor tube by pressing in the quick-release adaptor and lifting at the same time. Next, reach behind it to remove the motor control cable by twisting the metal nut counter-clockwise.
2. Remove the 12-pin controller cable from the bottom of the Sample Module which is connected through to the electronic box.
3. Unscrew the two brass-headed bolts in the front of the electronic box.
4. Now remove the electronic box.

Mass Flow Controller

The Mass Flow Controller can be removed from the pump enclosure by following the directions below.

1. Remove the six (6) small screws from the front panel of the pump enclosure. The door will slide down and off.
2. Remove the hose that connects to the front of the MFC and runs to the air line on the enclosure wall.
3. Remove the hose that connects to the rear of the MFC and runs to the pump outlet.
4. Unscrew the two (2) flathead screws holding the MFC data cable and remove the cable.
5. Unscrew the two (2) Philip screws on the MFC base plate. The MFC and the base plate can now be removed. Save the mounting plate and send the MFC for repair or replacement.

Pump Removal

The 120V pump inside the pump enclosure may need to be serviced or replaced. To remove the pump, follow the steps below.

1. Unplug the power from the top outlet of the power terminal inside the pump enclosure.
2. Remove the four (4) nuts on the bottom of the pump enclosure.
3. Disconnect the hose that runs from the MFC to the pump.
4. Disconnect the outlet hose that runs from the pump through the bottom of the pump enclosure. Pull the hose out of the hole, bend slightly, and gently twist the connector and hose until removed.
5. Carefully lift the pump out of the base of the pump enclosure. Be aware that the pump is quite heavy and may take two hands to hold firmly.

Replacing Fuses/MOVs

In the Controller Module near the keypad/display (see Figure 9.18), there are two Metal Oxide Varistors (MOVs). The top MOV is a P18Z3 for the 12-volt power supply as noted by the red and black wires that lead to it. The bottom MOV is a P33Z5 for the 24-volt power supply as noted by the yellow and black wires that lead to it. If these become damaged, it may be necessary to replace them. Additionally, inside

the controller panel, behind the protective plate, each board has a 4A 250VAC fuse on the top left that may need to be replaced.

Cyclone Removal

In order to remove the cyclone, you must first release the filter cartridge by pressing the red “up” button on the electronic box. After removing the filter cartridge, follow the steps, above, to remove the electronic box. Note that the box does not have to be completely removed, but it is recommended for ease of cyclone removal. Proceed by unscrewing the ring that connects the cyclone to the inlet tee. Then lift up and carefully remove the cyclone and cassette manifold body.

Optional Pump Enclosure Heater

The installation of a pump enclosure heater is recommended for cold-weather environments. Contact URG for more information about purchasing and installing a heater.

Sampler Configuration Menu Tree

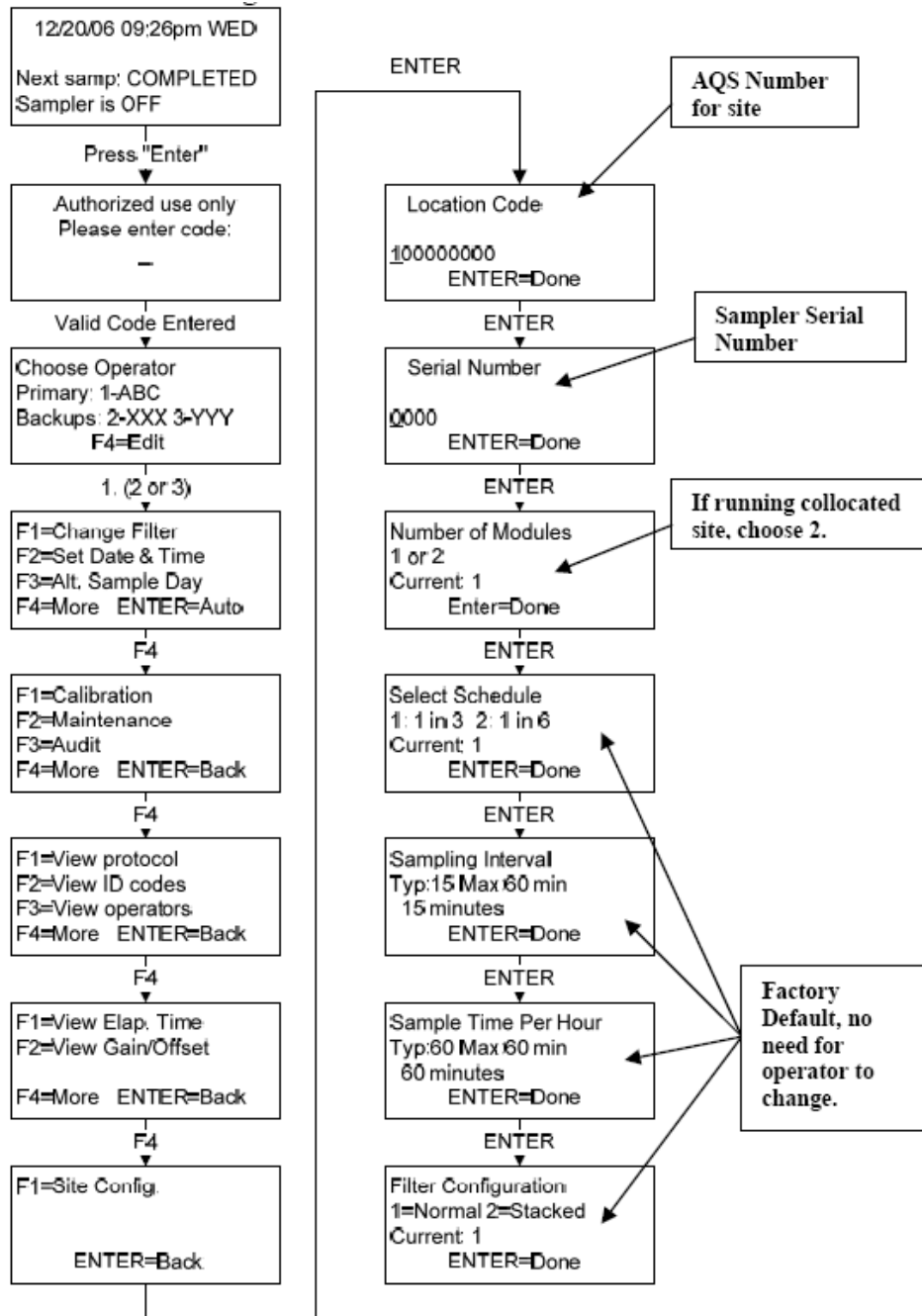

URG 3000N Sampler

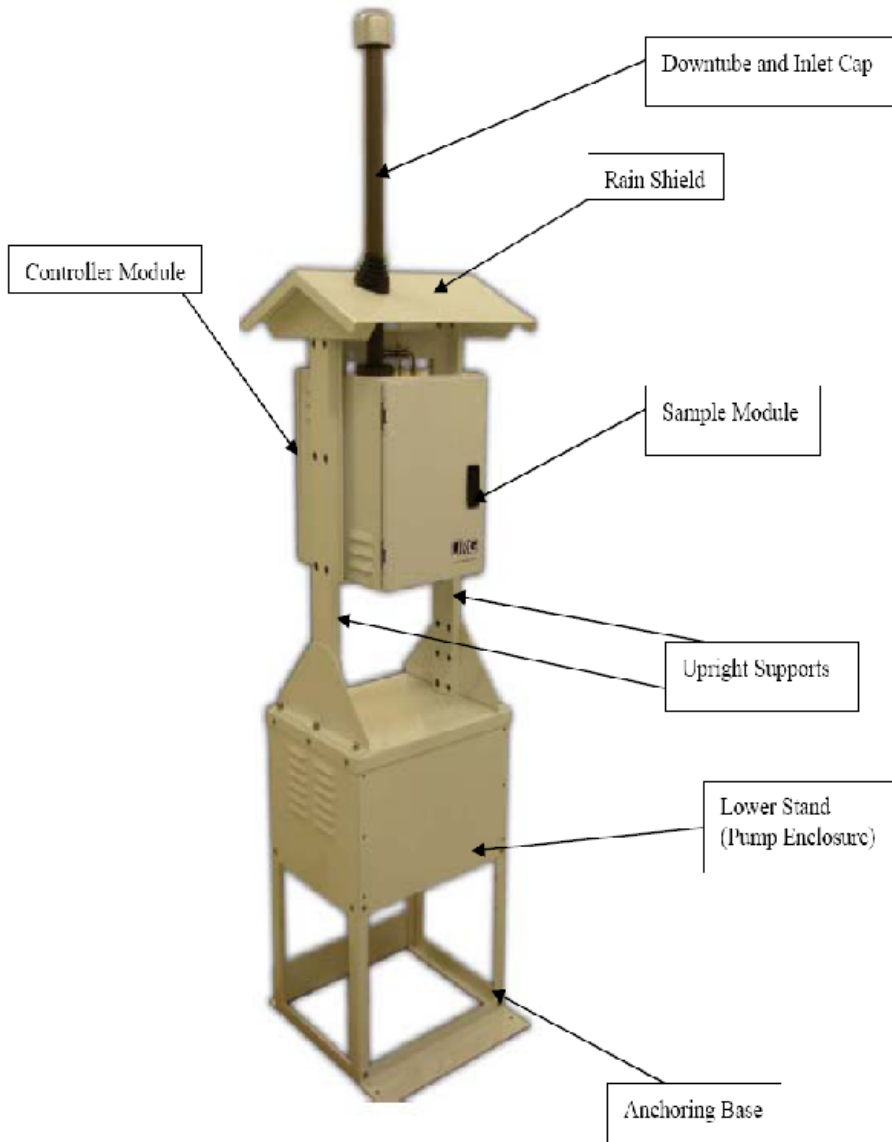

URG 3000N Pump and Control Box Connection Diagram

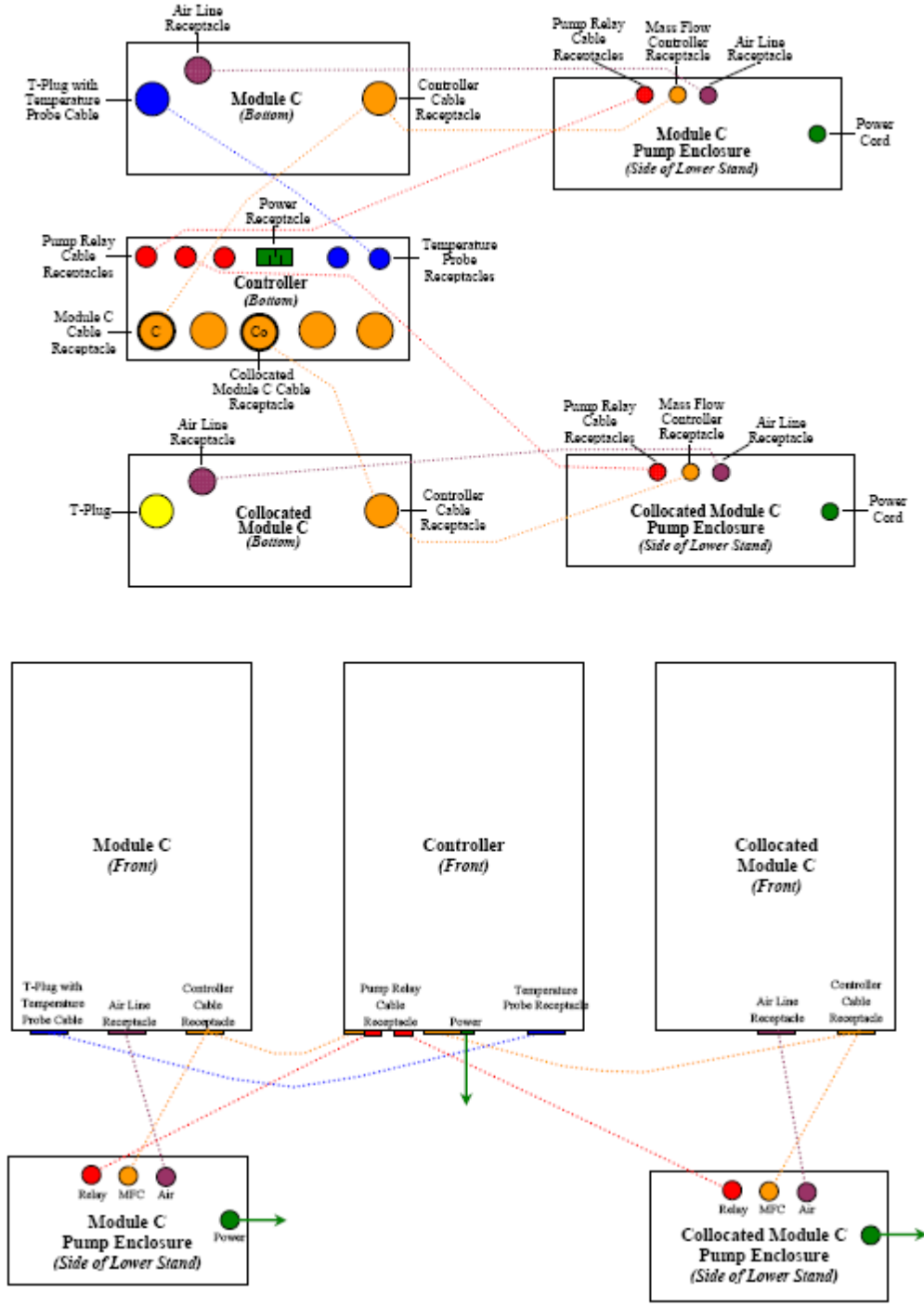

URG 3000N Sampler and Control Module

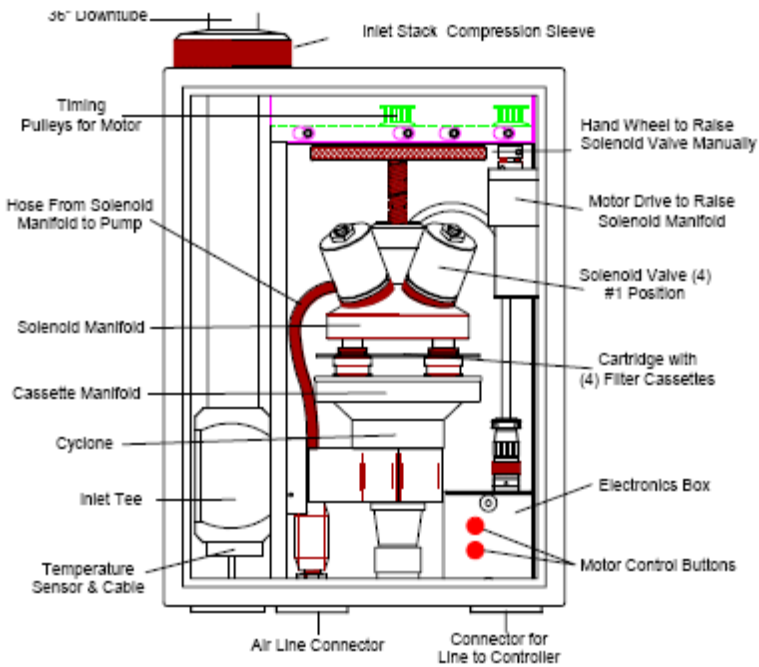
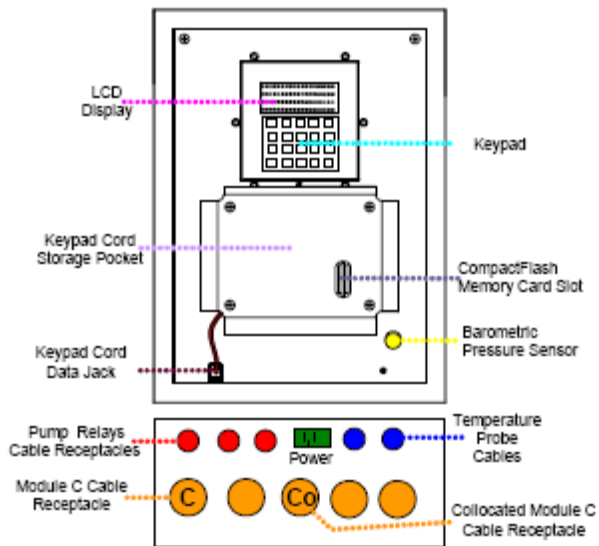
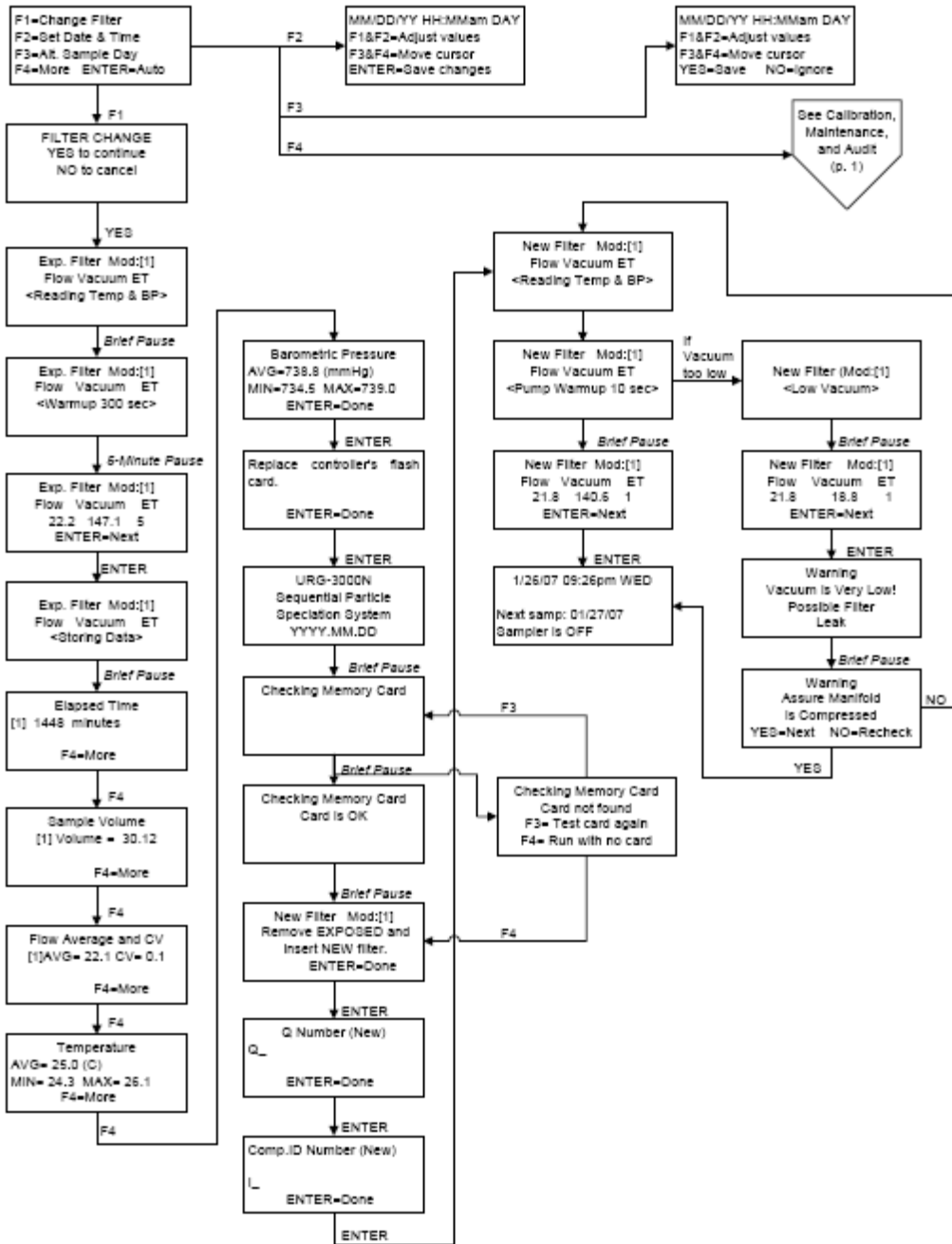

Figure C.2. Interior of the Sample Module



Filter Change and Scheduling Menu Tree

Filter Change and Scheduling





URG 3000N CSN Custody and Field Data Form (CUSTODY FORM) (CAFDF)

 Q135885G		PM 2.5 CSN CUSTODY AND FIELD DATA FORM TRAINING DATA FOR TRAINING USE ONLY		c. White (return to lab) c. Yellow (site retains) c. Pink (lab)				
A. CUSTODY RECORD (Name, Date)			Bin ID: B23102	Set: 6a				
1. Laboratory, Out _____		3. Site, Out _____						
2. Site, In _____		4. Lab, In _____						
B. SITE AND SAMPLER INFORMATION								
1. Site AIRS Code <u>490110004</u>		5. Site Name <u>Bountiful</u>						
2. Sampler S/N _____		6. Intended date of use <u>Friday, April 06, 2007</u>						
3. Sampler Type <u>URG 3000N</u>		7. Date of Sampler set-up _____						
4. Sampler POC <u>5</u>		8. Operator's name _____						
C. SAMPLER CHANNEL COMPONENTS								
Position	Component ID No.	Component Description						
1	I8018O	Quartz Cartridge ID						
1	I8019P	Memory Card ID						
D. START, END, AND RETRIEVAL TIMES								
Position	Start date	Start time	End date	End time	Retrieval date	Retrieval time		
1								
E. SAMPLER CHANNEL INFORMATION (Post-Sampling)								
Position	Run Time	Run Time, Flag	Sample Volume (m3)	Avg. flow (L/min)	Avg. flow CV (%)	Avg. ambient T (° C)	Max. ambient T (° C)	Min. ambient T (° C)
1								
Position	Avg. BP (mm Hg)	Max. BP (mm Hg)	Min. BP (mm Hg)					
1								
F. Comments _____ _____ _____								

URG 3000N APCD Field Verification Form

COLORADO DEPARTMENT OF PUBLIC HEALTH AND ENVIRONMENT
Air Pollution Control Division - Technical Services Program
PM_{2.5} STN Regular Maintenance/Sampler Verification Form

SITE/SAMPLER DATA
 Site Name: Commerce City STN Sampler Model: MetOne Sass Site Visit: A4907
 AIRS ID: 08-001-0006 Sampler S/N: A4907

	#1	#2	#3	#4	#5	#6	#7	#8	#9	#10
Operator										
Date										
Time										
Vis. Insp										
INSPECTION										
Inst. Mode										
Inst Condition										
Chan1Flow										
Chan2 Flow										
Chan3 Flow										
Temp. (T _A)										
Pres.(P _A)										

FTS S/N(lowflow): MJ387L FTS m = 0.4316 FTS b = -0.2589 Therm. S/N: 350042 Bar.S/N: Pretel/26754
 FTS S/N(CSN):

Four Week Instrument Verification										
Chan. #	Leak Rate OK?	Clock		Ambient Pres.		Amb. Temp.		FTS Pres	Channel Flow	
		Current	Standard	Current	Standard	Current	Standard		Inst.	Std.
1										
2										
3(CSN)										

Visit #	Time	Describe Action Due/Action Taken	Time On	Initials

TIME PERIOD: 01.05.09 to 02.01.09

LIST OF SCHEDULED EVENTS/ SCHEDULED DATES:
Scheduled Events: # 1 4-wk verification, 1st Stage Inlet Cleaning
SCHEDULED DATE: 01.05.09

Comments: _____

